

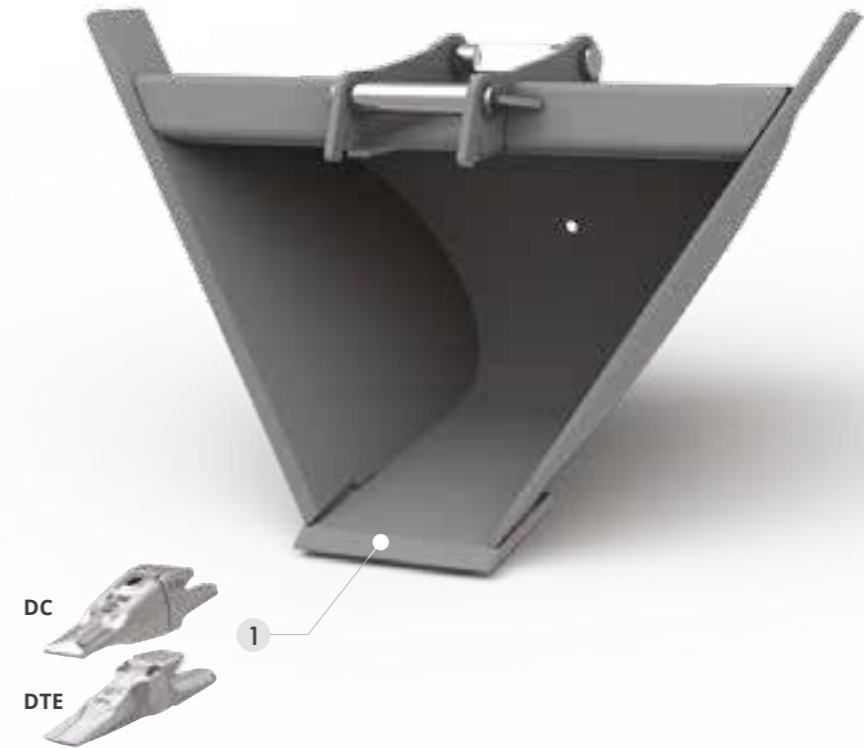

LA SUA FORMA A TRAPEZIO E LE POSSIBILI INCLINAZIONI DEI FIANCHI (52°-60°) PERMETTONO LA CREAZIONE E MANUTENZIONE DI FOSSI E CANALI DI DIVERSE DIMENSIONI E ANGOLAZIONI.



OPTIONAL

- 1 **DENTI DC** **DENTI DTE**

MOD.	T38	T45	T53	T62	T67	T73	T80	MIDI EXCAVATOR		T100 GD	T110 GD
								T85 GD	T92 GD		
TONS	0,6 - 1,8	1,8 - 2,5	2,5 - 4,0	4,0 - 5,0	5,0 - 7,5	7,5 - 10,0	10,0 - 12,0	12,0 - 14,0	12,0 - 14,0	14,0 - 18,0	18,0 - 22,0

T38 PESO MACCHINA 0,6 - 1,8

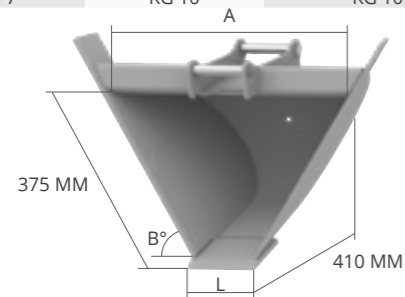

L MM	A MM	B°	PESO KG*	CAP. SAE L	ADAPTERS
200	607	52°	27	47	AF - AR - CS
					CR - CM
					CW - CS JANUS PRO
200	490	60°	24	37	AF - AR - CS
					CR - CM
					CW - CS JANUS PRO

OPTIONAL

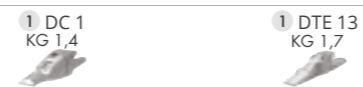

T45 PESO MACCHINA 1,8 - 2,5

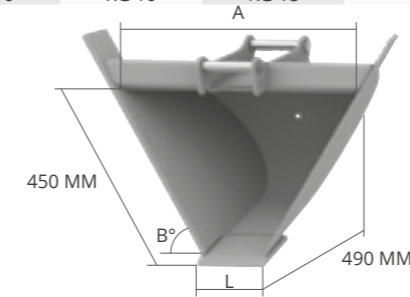
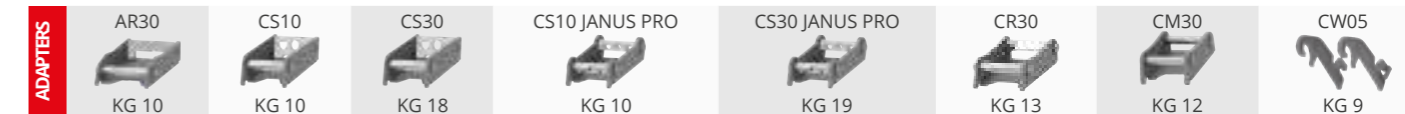

L MM	A MM	B°	PESO KG*	CAP. SAE L	ADAPTERS
250	741	52°	45	77	AF - AR - CS
					CR - CM
					CW - CS JANUS PRO
250	600	60°	40	63	AF - AR - CS
					CR - CM
					CW - CS JANUS PRO

OPTIONAL



T53 PESO MACCHINA 2,5 - 4,0

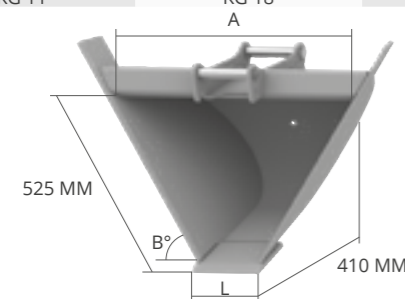
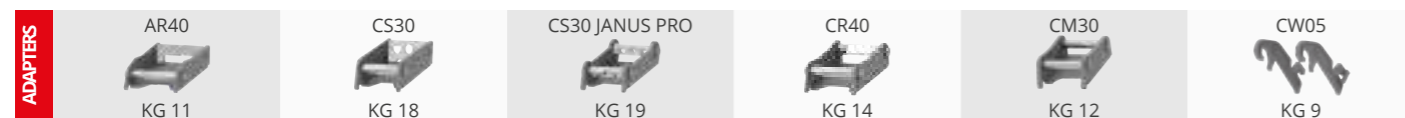

L MM	A MM	B°	PESO KG*	CAP. SAE L	ADAPTERS
300	868	52°	69	140	AF - AR - CS
					CR - CM
					CW - CS JANUS PRO
300	705	60°	61	114	AF - AR - CS
					CR - CM
					CW - CS JANUS PRO

OPTIONAL

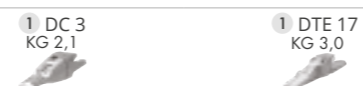

T62 PESO MACCHINA 4,0 - 5,0

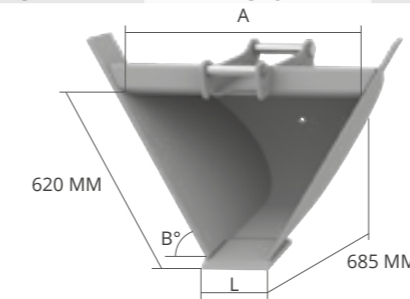
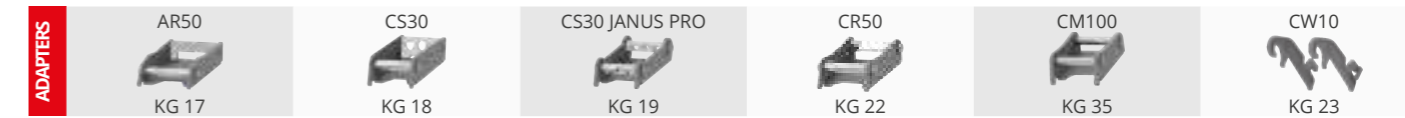

L MM	A MM	B°	PESO KG*	CAP. SAE L	ADAPTERS
300	985	52°	101	190	AF - AR - CS
					CR - CM
					CW - CS JANUS PRO
300	790	60°	88	153	AF - AR - CS
					CR - CM
					CW - CS JANUS PRO

OPTIONAL



* peso vasca escluso di attacchi e denti

* peso vasca escluso di attacchi e denti

T67 PESO MACCHINA 5,0 - 7,5

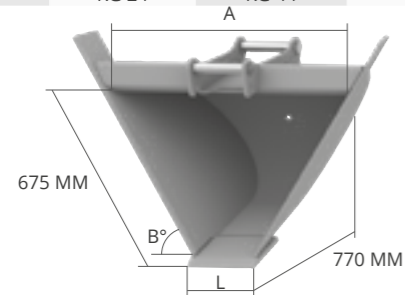

L MM	A MM	B°	PESO KG*	CAP. SAE L	ADAPTERS
350	1087	52°	144	239	AF - AR - CS
					CR - CM
					CW - CS JANUS PRO
350	876	60°	126	191	AF - AR - CS
					CR - CM
					CW - CS JANUS PRO

OPTIONAL

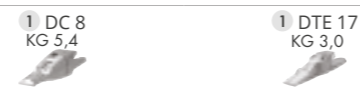

T73 PESO MACCHINA 7,5 - 10,0

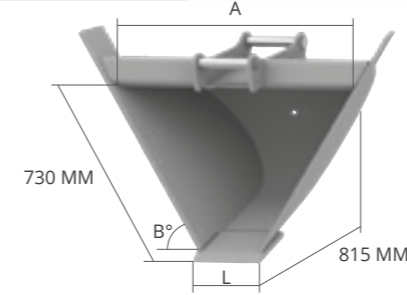

L MM	A MM	B°	PESO KG*	CAP. SAE L	ADAPTERS
350	1157	52°	166	318	AF - CS
					CR - CM
					CW - CS JANUS PRO
350	928	60°	146	254	AF - CS
					CR - CM
					CW - CS JANUS PRO

OPTIONAL

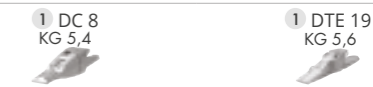

T80 PESO MACCHINA 10,0 - 12,0

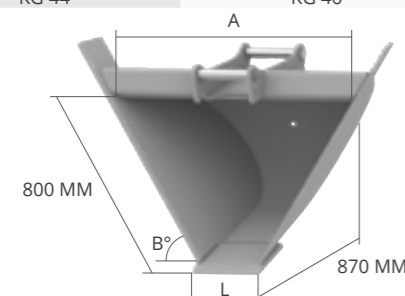

L MM	A MM	B°	PESO KG*	CAP. SAE L	ADAPTERS
350	1236	52°	207	355	AF - CS
					CR - CM - CS JANUS PRO
					CW
350	985	60°	184	281	AF - CS
					CR - CM - CS JANUS PRO
					CW

OPTIONAL



T85 GD MIDI PESO MACCHINA 12,0 - 14,0

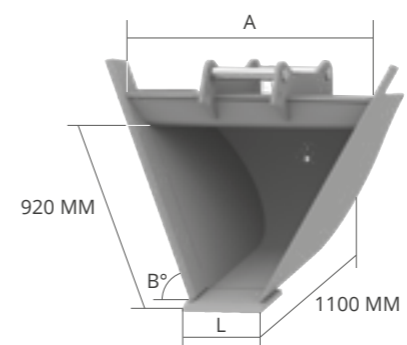
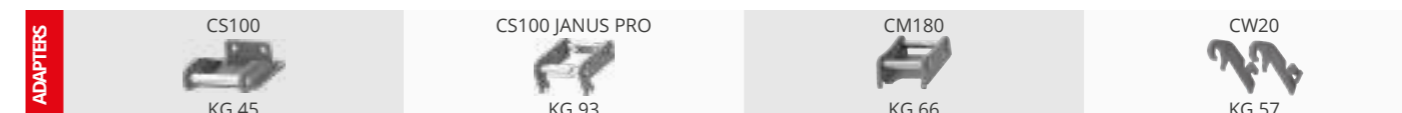

L MM	A MM	B°	PESO KG*	CAP. SAE L	ADAPTERS
350	1420	52°	320	430	AF - CM
					CS - CW
					CS JANUS PRO
350	1120	60°	275	370	AF - CM
					CS - CW
					CS JANUS PRO

OPTIONAL



* peso vasca escluso di attacchi e denti

* peso vasca escluso di attacchi e denti

T92 GD EXCAVATOR PESO MACCHINA 12,0 - 14,0

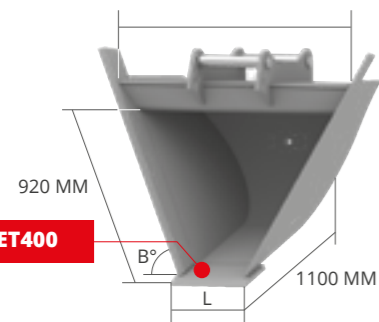
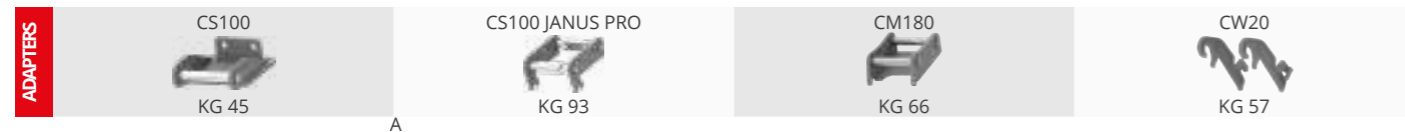

OPTIONAL



L MM	A MM	B°	PESO KG*	CAP. SAE L	ADAPTERS
400	1550	52°	400	540	AF - CM
					CS - CW
					CS JANUS PRO
400	1230	60°	340	470	AF - CM
					CS - CW
					CS JANUS PRO

T100 GD PESO MACCHINA 14,0 - 18,0

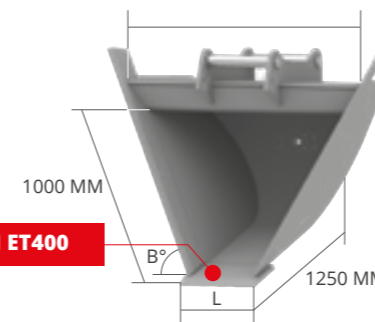
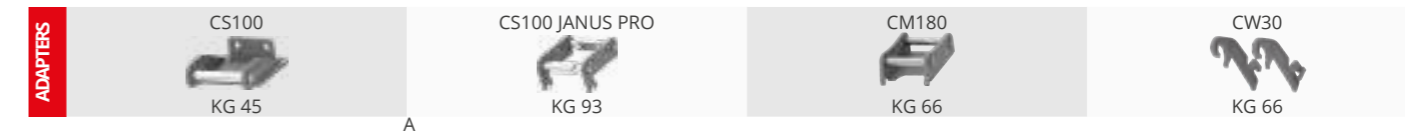

OPTIONAL

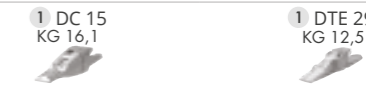

L MM	A MM	B°	PESO KG*	CAP. SAE L	ADAPTERS
400	1680	52°	530	680	AF - CM
					CS - CW
					CS JANUS PRO
400	1320	60°	455	585	AF - CM
					CS - CW
					CS JANUS PRO

T110 GD PESO MACCHINA 18,0 - 22,0

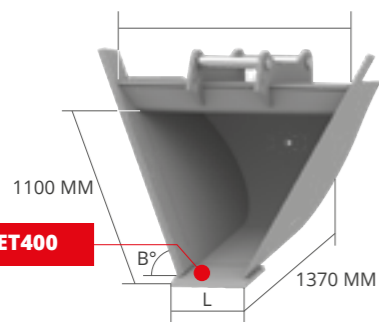
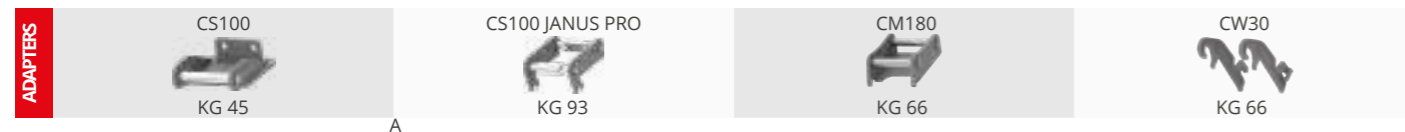

OPTIONAL

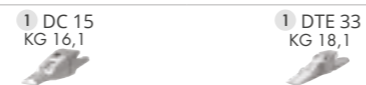

L MM	A MM	B°	PESO KG*	CAP. SAE L	ADAPTERS
400	1820	52°	660	870	AF - CM
					CS - CW
					CS JANUS PRO
400	1100	60°	565	740	AF - CM
					CS - CW
					CS JANUS PRO

* peso vasca escluso di attacchi e denti

* peso vasca escluso di attacchi e denti