

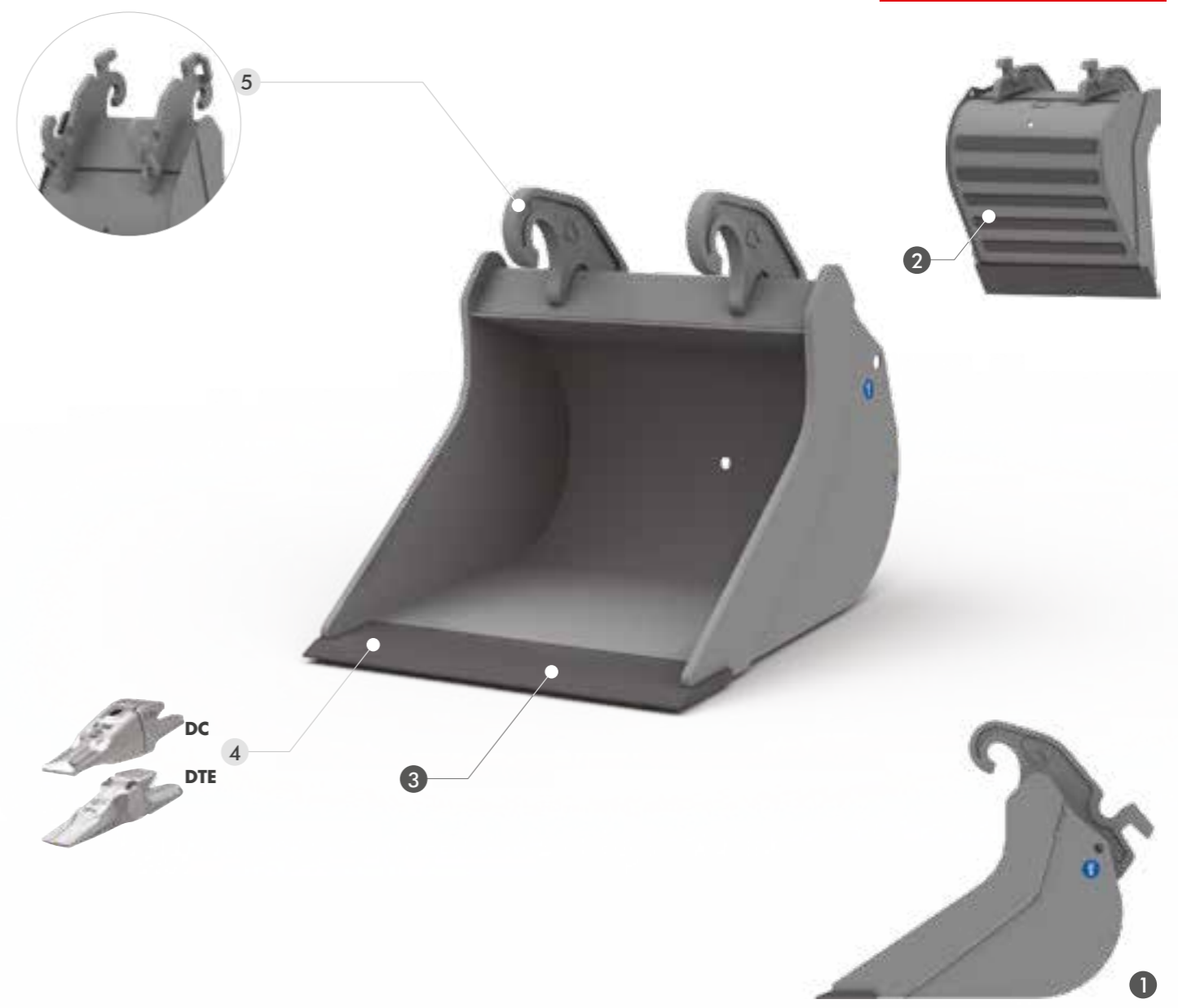

LA SUA FORMA ALLUNGATA EVITA CHE IL TERRENO ADERISCA ALLE PARETI LATERALI DELLA BENNA AGEVOLANDO LO SCARICO DI MATERIALI ARGILLOSI E BAGNATI. LA BENNA NETHERLANDS È DOTATA DI LAMA IN HB400.



**SPECIFICHE TECNICHE STANDARD**

- 1 **PROFILO ALLUNGATO**
- 2 **FASCE DI RINFORZO**  
LE FASCE DI RINFORZO ORIZZONTALI SALVAGUARDANO IL FONDO DALL'USURA AUMENTANDONE LA RESISTENZA.
- 3 **LAMA IN HB400**

**OPTIONAL**

- 4 **DENTI DC O DENTI DTE**
- 5 **VERSIONE REVERSIBILE CW**  
QUESTO PARTICOLARE ADATTORE PERMETTE DI RENDERE LA BENNA REVERSIBILE.

MOD.	SCN35	SCN41	SCN52	SCN60	SCN66	SCN75	SCN85
TONS	0,6 - 1,2	1,2 - 1,8	1,8 - 2,5	2,5 - 4,0	4,0 - 6,0	6,0 - 7,5	7,5 - 12,0

## SCN35 PESO MACCHINA 0,6 - 1,2

ADAPTERS

CW5



KG 9

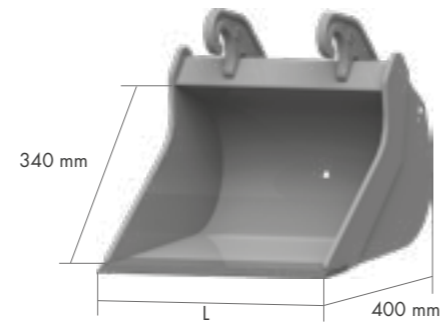

### OPTIONAL

4	4	5
Denti DC	Denti DTE	Versione reversibile CW

L mm	PESO Kg*	CAP. SAE l	
300	19	21	AF
300	19	21	CW
400	23	31	AF
400	23	31	CW
500	28	47	AF
500	28	47	CW

## SCN41 PESO MACCHINA 1,2 - 1,8

ADAPTERS

CW5



KG 9



### OPTIONAL

4	4	5
Denti DC	Denti DTE	Versione reversibile CW

L mm	PESO Kg*	CAP. SAE l	
300	22	26	AF
300	22	26	CW
400	27	38	AF
400	27	38	CW
500	33	52	AF
500	33	52	CW
600	38	75	AF
600	38	75	CW

## SCN52 PESO MACCHINA 1,8 - 2,5

ADAPTERS

CW5



KG 9

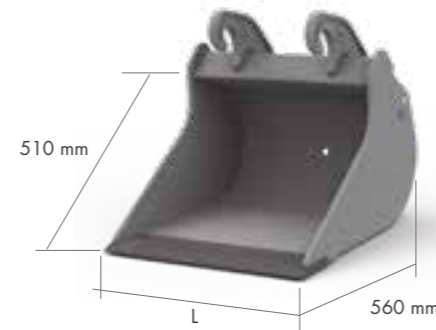

### OPTIONAL

4	4	5
Denti DC	Denti DTE	Versione reversibile CW

L mm	PESO Kg*	CAP. SAE l	
300	32	34	AF
300	32	34	CW
400	40	51	AF
400	40	51	CW
500	47	69	AF
500	47	69	CW
600	54	87	AF
600	54	87	CW

## SCN60 PESO MACCHINA 2,5 - 4,0

ADAPTERS

CW5



KG 9

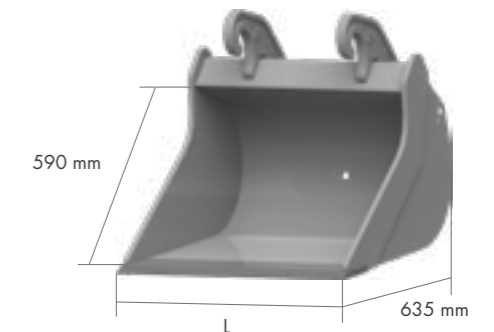

### OPTIONAL

4	4	5
Denti DC	Denti DTE	Versione reversibile CW

L mm	PESO Kg*	CAP. SAE l	
300	41	46	AF
300	41	46	CW
400	49	69	AF
400	49	69	CW
500	57	93	AF
500	57	93	CW
600	65	118	AF
600	65	118	CW

\* peso vasca escluso di attacchi e denti

\* peso vasca escluso di attacchi e denti

## SCN66 PESO MACCHINA 4,0 - 6,0

ADAPTERS

CW10



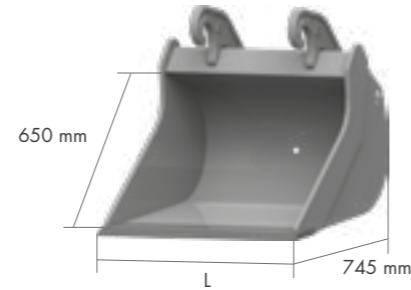

KG 23



L mm	PESO Kg*	CAP. SAE l	
400	65	79	AF
400	65	79	CW
500	75	107	AF
500	75	107	CW
600	86	137	AF
600	86	137	CW
700	97	168	AF
700	97	168	CW

### OPTIONAL

		
Denti DC	Denti DTE	Versione reversibile CW

## SCN75 PESO MACCHINA 6,0 - 7,5

ADAPTERS

CW10



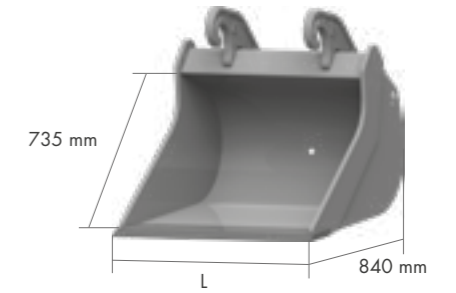

KG 23



L mm	PESO Kg*	CAP. SAE l	
400	85	94	AF
400	85	94	CW
500	100	128	AF
500	100	128	CW
600	114	165	AF
600	114	165	CW
700	128	203	AF
700	128	203	CW
800	142	243	AF
800	142	243	CW

### OPTIONAL

		
Denti DC	Denti DTE	Versione reversibile CW

## SCN85 PESO MACCHINA 7,5 - 12,0

ADAPTERS

CW10



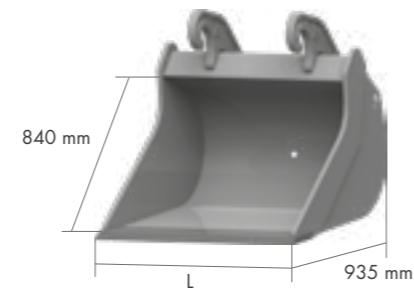

KG 23



L mm	PESO Kg*	CAP. SAE l	
400	98	121	AF
400	98	121	CW
500	112	160	AF
500	112	160	CW
600	127	205	AF
600	127	205	CW
700	142	252	AF
700	142	252	CW
800	157	301	AF
800	157	301	CW
900	172	352	AF
900	172	352	CW

### OPTIONAL

		
Denti DC	Denti DTE	Versione reversibile CW

\* peso vasca escluso di attacchi e denti

\* peso vasca escluso di attacchi e denti