



HB400



LA SUA FORMA ALLUNGATA EVITA CHE IL TERRENO ADERISCA ALLE PARETI LATERALI DELLA BENNA AGEVOLANDO LO SCARICO DI MATERIALI ARGILLOSI E BAGNATI. LE FIANCATE INCAVATE FACILITANO LE OPERAZIONI DI ATTRAVERSAMENTO DI IMPIANTI IDRAULICI, GAS ETC. LA LAMA È IN HB400 PER UNA MAGGIORE RESISTENZA ALL'USURA.

MOD.	MIDI								EXCAVATOR			
	BS 35GD	BS 40GD	BS 48GD	BS 60GD	BS 67GD	BS 71GD	BS 75GD	BS 80GD	BS 85GD	BS 92GD	BS 100GD	BS 110GD
TONS	0,8 - 1,5	1,5 - 2,0	2,0 - 3,0	3,0 - 4,0	4,0 - 6,0	6,0 - 7,5	7,5 - 9,0	9,0 - 12,0	12,0 - 14,0	12,0 - 14,0	14,0 - 18,0	18,0 - 22,0

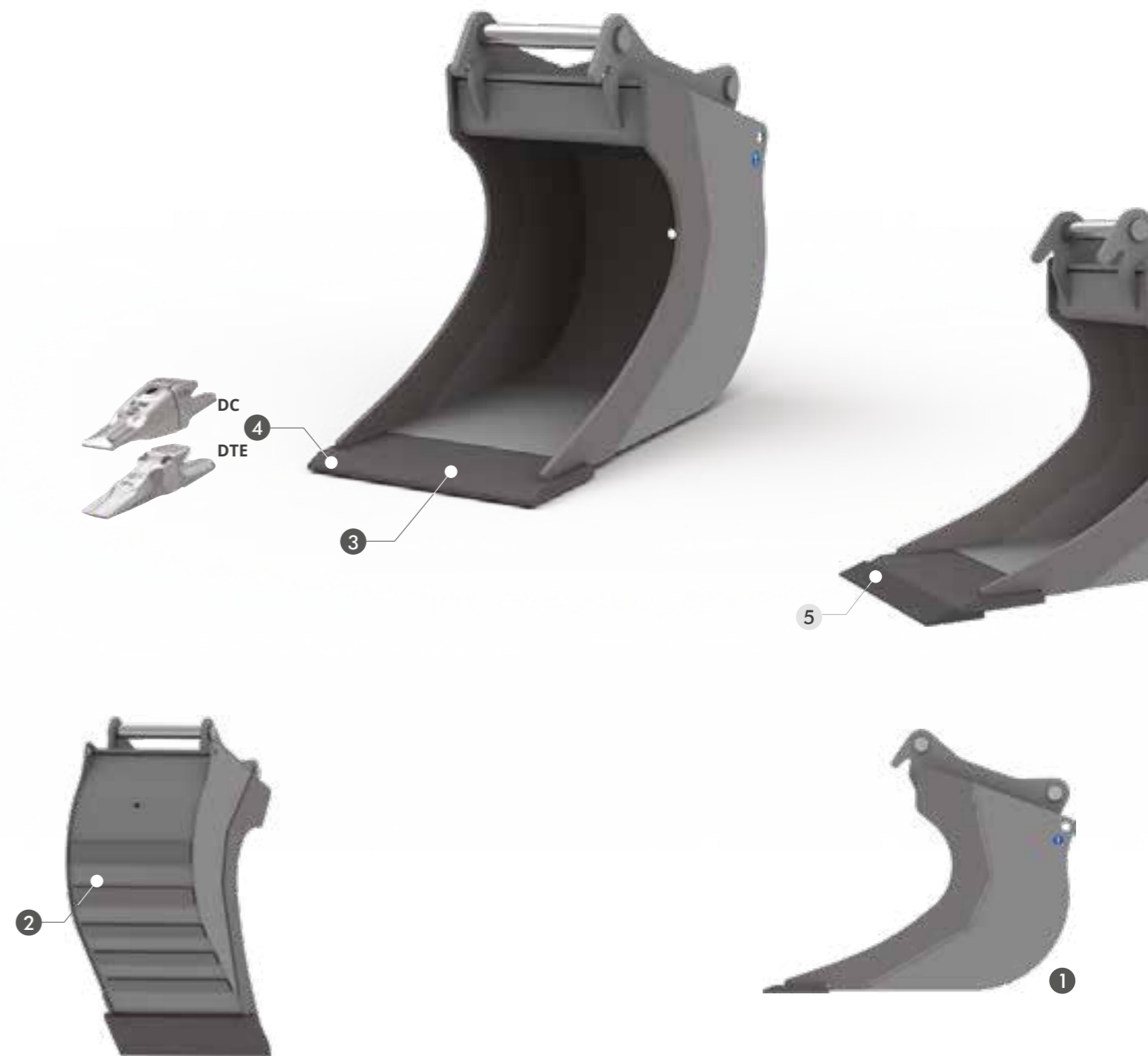

### SPECIFICHE TECNICHE STANDARD

- 1 **PROFILO ALLUNGATO**
- 2 **FASCE DI RINFORZO**  
LE FASCE DI RINFORZO ORIZZONTALI SALVAGUARDANO IL FONDO DALL'USURA AUMENTANDONE LA RESISTENZA.
- 3 **LAMA IN HB400**
- 4 **DENTI DC DENTI DTE**

### OPTIONAL

- 5 **SOTTOLAMA SALDATO IN HB500**  
CONSIGLIATO PER OPERARE SU TERRENI PARTICOLARMENTE ABRASIVI.



## BS35 GD PESO MACCHINA 0,8 - 1,5

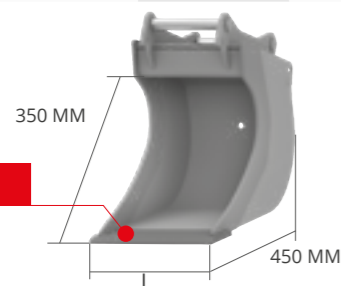

LAMA IN HB400

### OPTIONAL

5  
SOTTOLAMA  
SALDATO HB500

L MM	PESO KG*	CAP. SAE L	DENTI N°	ADAPTERS
250	20	24	3	AF - AR - CS
				CR - S - CM
				CW - CS JANUS PRO
300	22	29	3	AF - AR - CS
				CR - S - CM
				CW - CS JANUS PRO
350	25	35	3	AF - AR - CS
				CR - S - CM
				CW - CS JANUS PRO
400	28	41	3	AF - AR - CS
				CR - S - CM
				CW - CS JANUS PRO

## BS40 GD PESO MACCHINA 1,5 - 2,0

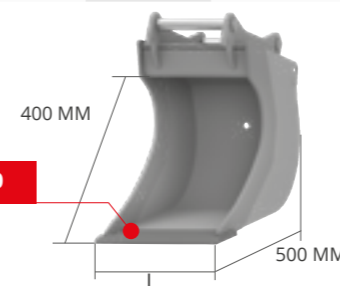

LAMA IN HB400

### OPTIONAL

5  
SOTTOLAMA  
SALDATO HB500

L MM	PESO KG*	CAP. SAE L	DENTI N°	ADAPTERS
250	23	24	3	AF - AR - CS
				CR - S - CM
				CW - CS JANUS PRO
300	25	30	3	AF - AR - CS
				CR - S - CM
				CW - CS JANUS PRO
350	27	37	3	AF - AR - CS
				CR - S - CM
				CW - CS JANUS PRO
400	30	44	3	AF - AR - CS
				CR - S - CM
				CW - CS JANUS PRO

## BS48 GD PESO MACCHINA 2,0 - 3,0

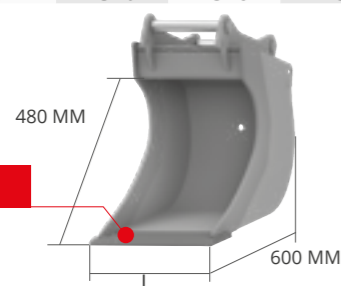

LAMA IN HB400

### OPTIONAL

5  
SOTTOLAMA  
SALDATO HB500

L MM	PESO KG*	CAP. SAE L	DENTI N°	ADAPTERS
250	33	36	3	AF - AR - CS
				CR - S - CM
				CW - CS JANUS PRO
300	38	45	3	AF - AR - CS
				CR - S - CM
				CW - CS JANUS PRO
350	42	54	3	AF - AR - CS
				CR - S - CM
				CW - CS JANUS PRO
400	48	63	3	AF - AR - CS
				CR - S - CM
				CW - CS JANUS PRO
500	58	83	4	AF - AR - CS
				CR - S - CM
				CW - CS JANUS PRO

## BS60 GD PESO MACCHINA 3,0 - 4,0

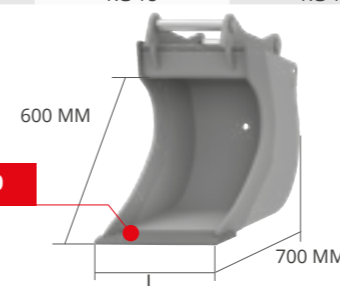

LAMA IN HB400

### OPTIONAL

5  
SOTTOLAMA  
SALDATO HB500

L MM	PESO KG*	CAP. SAE L	DENTI N°	ADAPTERS
250	40	54	3	AF - AR - CS
				CR - S - CM
				CW - CS JANUS PRO
300	45	66	3	AF - AR - CS
				CR - S - CM
				CW - CS JANUS PRO
350	51	79	3	AF - AR - CS
				CR - S - CM
				CW - CS JANUS PRO
400	57	93	3	AF - AR - CS
				CR - S - CM
				CW - CS JANUS PRO
500	68	121	4	AF - AR - CS
				CR - S - CM
				CW - CS JANUS PRO

\* peso vasca escluso di attacchi e denti

\* peso vasca escluso di attacchi e denti

## BS67 GD PESO MACCHINA 4,0 - 6,0

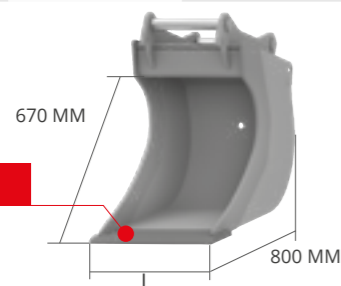
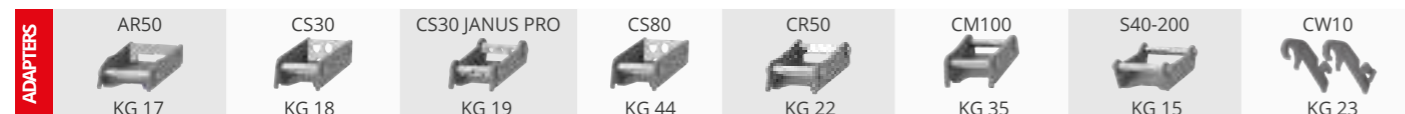

LAMA IN HB400

### OPTIONAL

5  
SOTTOLAMA  
SALDATO HB500

L MM	PESO KG*	CAP. SAE L	DENTI N°	ADAPTERS
300	60	78	3	AF - AR - CS
				CR - S - CM
				CW - CS JANUS PRO
350	69	95	3	AF - AR - CS
				CR - S - CM
				CW - CS JANUS PRO
400	78	111	3	AF - AR - CS
				CR - S - CM
				CW - CS JANUS PRO
500	95	146	4	AF - AR - CS
				CR - S - CM
				CW - CS JANUS PRO

## BS71 GD PESO MACCHINA 6,0 - 7,5

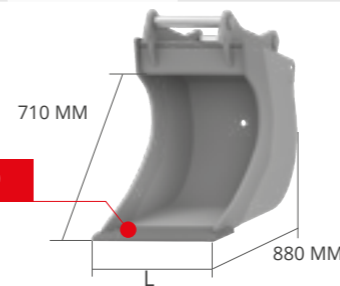

LAMA IN HB400

### OPTIONAL

5  
SOTTOLAMA  
SALDATO HB500

L MM	PESO KG*	CAP. SAE L	DENTI N°	ADAPTERS
350	88	112	3	AF - AR - CS
				CR - S - CM
				CW - CS JANUS PRO
400	96	132	3	AF - AR - CS
				CR - S - CM
				CW - CS JANUS PRO
500	116	172	3	AF - AR - CS
				CR - S - CM
				CW - CS JANUS PRO
600	133	215	4	AF - AR - CS
				CR - S - CM
				CW - CS JANUS PRO

## BS75 GD PESO MACCHINA 7,5 - 9,0

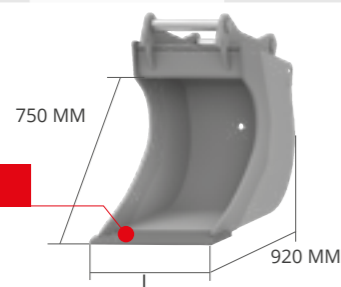

LAMA IN HB400

### OPTIONAL

5  
SOTTOLAMA  
SALDATO HB500

L MM	PESO KG*	CAP. SAE L	DENTI N°	ADAPTERS
350	92	117	3	AF - CS
				CR - S - CM
				CW - CS JANUS PRO
400	102	138	3	AF - CS
				CR - S - CM
				CW - CS JANUS PRO
500	120	181	3	AF - CS
				CR - S - CM
				CW - CS JANUS PRO
600	140	226	4	AF - CS
				CR - S - CM
				CW - CS JANUS PRO

## BS80 GD PESO MACCHINA 9,0 - 12,0

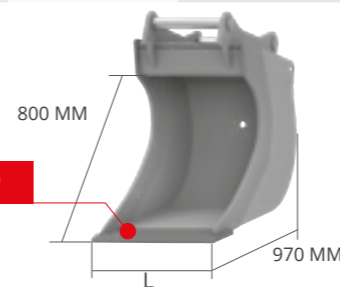

LAMA IN HB400

### OPTIONAL

5  
SOTTOLAMA  
SALDATO HB500

L MM	PESO KG*	CAP. SAE L	DENTI N°	ADAPTERS
400	115	161	3	AF - CS
				CR - S - CM
				CW - CS JANUS PRO
500	140	210	3	AF - CS
				CR - S - CM
				CW - CS JANUS PRO
600	165	261	3	AF - CS
				CR - S - CM
				CW - CS JANUS PRO

\* peso vasca escluso di attacchi e denti

\* peso vasca escluso di attacchi e denti

## BS85 GD **MIDI** PESO MACCHINA 12,0 - 14,0

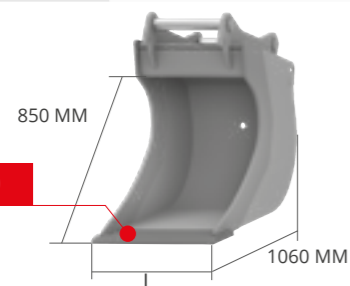

LAMA IN HB400

### OPTIONAL

5  
SOTTOLAMA  
SALDATO HB500

L MM	PESO KG*	CAP. SAE L	DENTI N°	ADAPTERS
400	145	184	3	AF - S - CM
				CS - CW
				CS JANUS PRO
500	170	242	3	AF - S - CM
				CS - CW
				CS JANUS PRO
600	195	301	4	AF - S - CM
				CS - CW
				CS JANUS PRO

## BS92 GD **EXCAVATOR** PESO MACCHINA 12,0 - 14,0

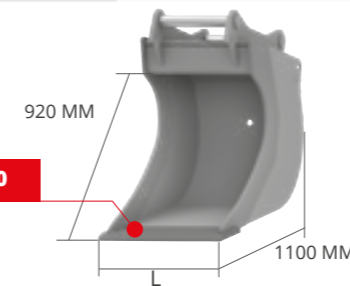

LAMA IN HB400

### OPTIONAL

5  
SOTTOLAMA  
SALDATO HB500

L MM	PESO KG*	CAP. SAE L	DENTI N°	ADAPTERS
400	162	206	3	AF - S - CM
				CS - CW
				CS JANUS PRO
500	195	270	3	AF - S - CM
				CS - CW
				CS JANUS PRO
600	223	337	4	AF - S - CM
				CS - CW
				CS JANUS PRO

## BS100 GD PESO MACCHINA 14,0 - 18,0

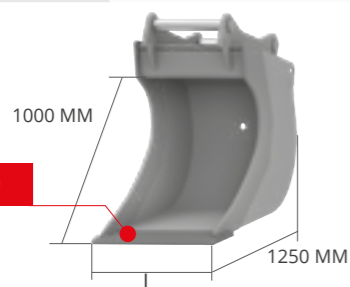

LAMA IN HB400

### OPTIONAL

5  
SOTTOLAMA  
SALDATO HB500

L MM	PESO KG*	CAP. SAE L	DENTI N°	ADAPTERS
400	230	245	3	AF - S - CM
				CS - CW
				CS JANUS PRO
500	268	320	3	AF - S - CM
				CS - CW
				CS JANUS PRO
600	306	398	3	AF - S - CM
				CS - CW
				CS JANUS PRO

## BS110 GD PESO MACCHINA 18,0 - 22,0

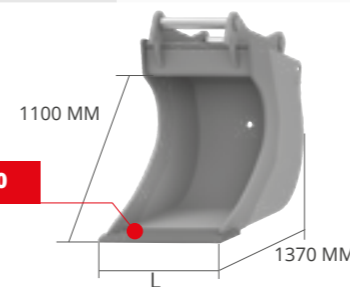

LAMA IN HB400

### OPTIONAL

5  
SOTTOLAMA  
SALDATO HB500

L MM	PESO KG*	CAP. SAE L	DENTI N°	ADAPTERS
400	300	283	3	AF - S - CM
				CS - CW
				CS JANUS PRO
500	345	372	3	AF - S - CM
				CS - CW
				CS JANUS PRO
600	390	464	3	AF - S - CM
				CS - CW
				CS JANUS PRO

\* peso vasca escluso di attacchi e denti

\* peso vasca escluso di attacchi e denti