

LA SUA FORMA ALLUNGATA EVITA CHE IL TERRENO ADERISCA ALLE PARETI LATERALI DELLA BENNA AGEVOLANDO LO SCARICO DI MATERIALI ARGILLOSI E BAGNATI. LE FIANCATE INCAVATE FACILITANO LE OPERAZIONI DI ATTRAVERSAMENTO DI IMPIANTI IDRAULICI, GAS ETC. LA BENNA NETHERLANDS È DOTATA DI LAMA IN HB400.

**SPECIFICHE TECNICHE STANDARD**

- 1 PROFILO ALLUNGATO**
- 2 FASCE DI RINFORZO**  
LE FASCE DI RINFORZO ORIZZONTALI SALVAGUARDANO IL FONDO DALL'USURA AUMENTANDONE LA RESISTENZA.
- 3 LAMA IN HB400**

**OPTIONAL**

- 4 DENTI DC O DENTI DTE**
- 5 VERSIONE REVERSIBILE CW**  
QUESTO PARTICOLARE ADATTORE PERMETTE DI RENDERE LA BENNA REVERSIBILE.

MOD.	BN35	BN41	BN52	BN60	BN66	BN75	BN90
TONS	0,6 - 1,2	1,2 - 1,8	1,8 - 2,5	2,5 - 4,0	4,0 - 6,0	6,0 - 7,5	7,5 - 12,0

## BN35 PESO MACCHINA 0,6 - 1,2

ADAPTERS

CW5  
KG 9

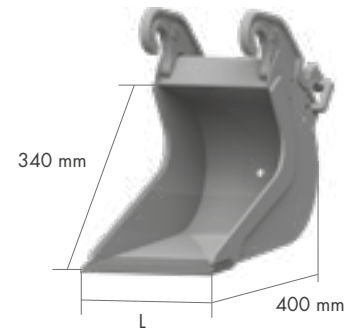

L mm	PESO KG*	CAP. SAE l	
220	17	16	AF
220	17	16	CW
250	18	18	AF
250	18	18	CW
300	20	22	AF
300	20	22	CW

### OPTIONAL

4	4	5
Denti DC	Denti DTE	Versione reversibile CW

## BN41 PESO MACCHINA 1,2 - 1,8

ADAPTERS

CW5  
KG 9

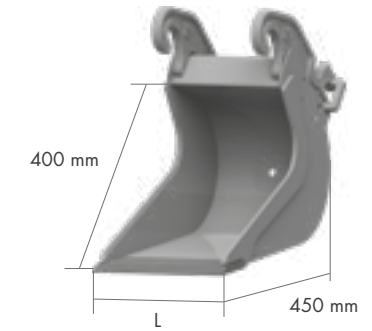

L mm	PESO Kg*	CAP. SAE l	
220	19	20	AF
220	19	20	CW
250	20	23	AF
250	20	23	CW
300	22	28	AF
300	22	28	CW
350	24	34	AF
350	24	34	CW

### OPTIONAL

4	4	5
Denti DC	Denti DTE	Versione reversibile CW

## BN52 PESO MACCHINA 1,8 - 2,5

ADAPTERS

CW5  
KG 9

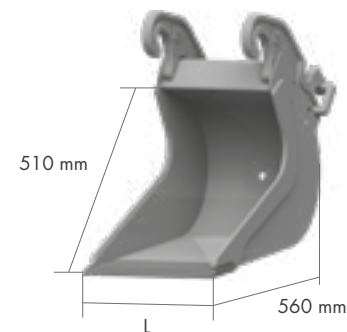

L mm	PESO Kg*	CAP. SAE l	
220	25	27	AF
220	25	27	CW
250	27	32	AF
250	27	32	CW
300	29	38	AF
300	29	38	CW
350	33	46	AF
350	33	46	CW

### OPTIONAL

4	4	5
Denti DC	Denti DTE	Versione reversibile CW

## BN60 PESO MACCHINA 2,5 - 4,0

ADAPTERS

CW5  
KG 9

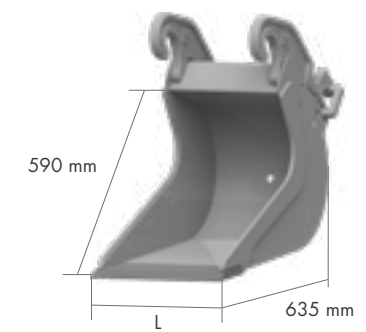

L mm	PESO Kg*	CAP. SAE l	
220	31	38	AF
220	31	38	CW
250	33	45	AF
250	33	45	CW
300	36	53	AF
300	36	53	CW
350	40	65	AF
350	40	65	CW
400	44	77	AF
400	44	77	CW

### OPTIONAL

4	4	5
Denti DC	Denti DTE	Versione reversibile CW

\* peso vasca escluso di attacchi e denti

\* peso vasca escluso di attacchi e denti

## BN66 PESO MACCHINA 4,0 - 6,0

ADAPTERS

CW10



KG 23

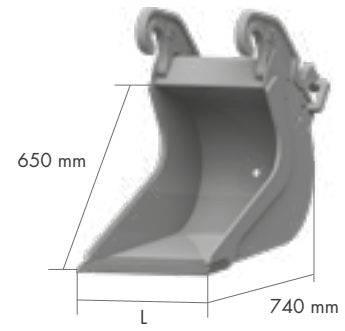

### OPTIONAL

4	4	5
Denti DC	Denti DTE	Versione reversibile CW

L mm	PESO Kg*	CAP. SAE l	
220	39	42	AF
220	39	42	CW
250	42	50	AF
250	42	50	CW
300	48	77	AF
300	48	77	CW
350	51	83	AF
350	51	83	CW
400	56	92	AF
400	56	92	CW

## BN75 PESO MACCHINA 6,0 - 7,5

ADAPTERS

CW10



KG 23

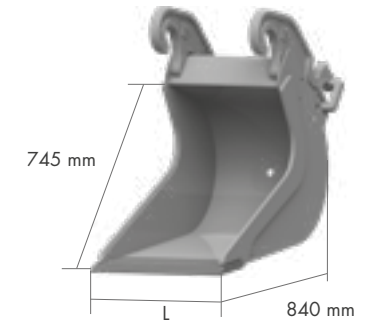

L mm	PESO Kg*	CAP. SAE l	
250	67	59	AF
250	67	59	CW
300	71	74	AF
300	71	74	CW
350	73	91	AF
350	73	91	CW
400	74	106	AF
400	74	106	CW

### OPTIONAL

4	4	5
Denti DC	Denti DTE	Versione reversibile CW

## BN90 PESO MACCHINA 7,5 - 12,0

ADAPTERS

CW10



KG 23

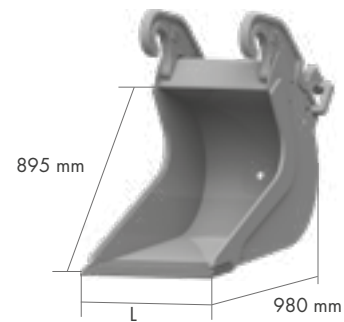

### OPTIONAL

4	4	5
Denti DC	Denti DTE	Versione reversibile CW

L mm	PESO Kg*	CAP. SAE l	
300	90	78	AF
300	90	78	CW
350	96	100	AF
350	96	100	CW
400	100	123	AF
400	100	123	CW
450	106	146	AF
450	106	146	CW
500	115	171	AF
500	115	171	CW

\* peso vasca escluso di attacchi e denti

\* peso vasca escluso di attacchi e denti